



Macadams

Heavy Duty Moulder



FEATURES & BENEFITS

- Superb results in moulding tin bread
- Sheeting rollers are of non-stick nylon compound.
- Regulates moulding pressure and length of dough pieces.





Technical Specs

| | Heavy Duty Moulder |
|-------------------------|--|
| Power Rating (kW) | 2.6 |
| Supply Voltage | 230 / 400 V, 50 Hz 3 phase, neutral and earth |
| Current Rating at 400 V | 4 A |
| Belt Drive (kW) | 1.1 |
| Sheeting Rollers (kW) | 1.5 |
| Capacity | Up to 3000 pieces per hour. |
| Dough Weight Range (g) | 100 g - 1000 |
| Moulding Length (mm) | Up to 450 |
| Weight (kg) | 559 |

FRONT VIEW

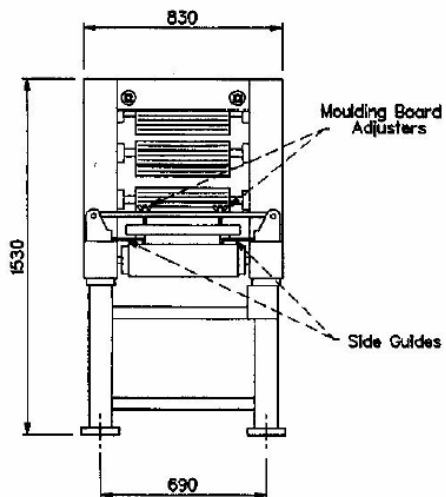

SIDE VIEW

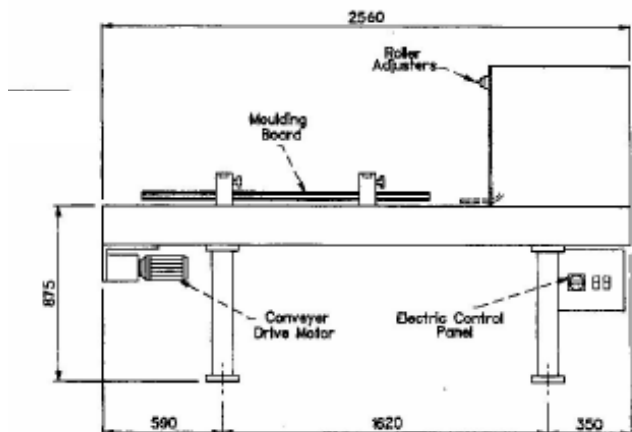

Contact Details

HEAD OFFICE, EXPORTS & CAPE TOWN BRANCH Tel : +27 (21) 907-1000 Fax : +27 (21) 907-1111

JOHANNESBURG BRANCH Tel : (011) 472-4100 Fax : 086 618 6462

DURBAN BRANCH Tel : (031) 569-6290 Fax : (031) 569-6296

EMAIL info@macadams.co.za

WEBSITE www.macadams.co.za

Macadams

MO-881 Moulder



FEATURES & BENEFITS

- Heavy duty moulder for use in industrial bakeries.
- Triple moulding head, curling net and double pressure boards.
- Driven by tension timing belt, noiseless and sustainable. Collection tray with two positions enables outfeed with or without stop.
- Three adjustable pressure rollers with spring loaded scrapers for easy cleaning.
- Two separate pressure boards:
 - First pressure board is delivered in two widths, 220 and 280 mm
 - Foldable, second pressure board 650 x 1100 mm for easy cleaning
- Handles on left or right side must be indicated upon order.



| | MO -881 |
|---|---|
| Capacity Range | Up to 3600 dough pieces/hour* |
| Weight range (g) | 30g – 1800g |
| Working width (mm) | Up to 650mm |
| Power Supply (kW) | 1.1 |
| Weight, net (kg) | 630kg |
| Weight, gross (Carton + Pallet) (kg) | 745kg |
| Volume, gross | 3.15 x 1.15 x 2.00 = 7.25m ³ |
| Stock Code | GLM-90002 |

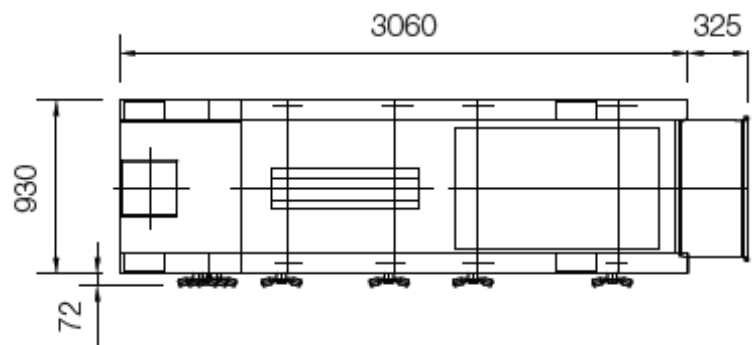
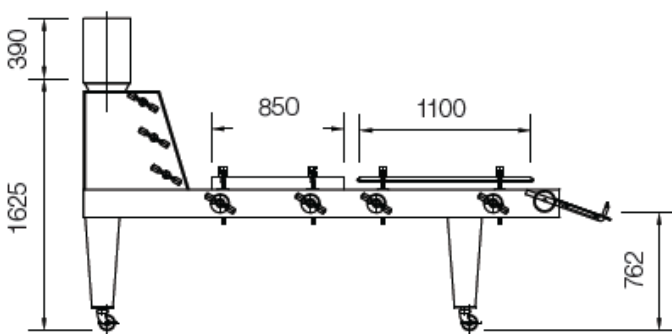

Contact Details

HEAD OFFICE, EXPORTS & CAPE TOWN BRANCH Tel : +27 (21) 907-1000 Fax : +27 (21) 907-1111

JOHANNESBURG BRANCH Tel : (011) 472-4100 Fax : 086 618 6462

DURBAN BRANCH Tel : (031) 569-6290 Fax : (031) 569-6296

EMAIL info@macadams.co.za

WEBSITE www.macadams.co.za



Macadams

French Baguette Moulder



FEATURES & BENEFITS

- Heavy framed thick Aluminium body.
- Emergency stop button.
- One input cylinder to make rolling easy.



| | SM 380 |
|-----------------------------------|--|
| Power Rating (kW) | 0.375 |
| Supply Voltage | 230 / 400 V, 50 Hz 3 phase, neutral & earth |
| Current Rating at 400 V | 1 A |
| Weight Range for Dough Pieces (g) | 50 - 900 |
| Average Output | 2500 pieces per hour. |
| Dimensions (mm) | 970(W) x 685(D) x 1600(H) |
| Weight: (kg) | |
| Net (with stand) | 250 |
| Gross | 300 |

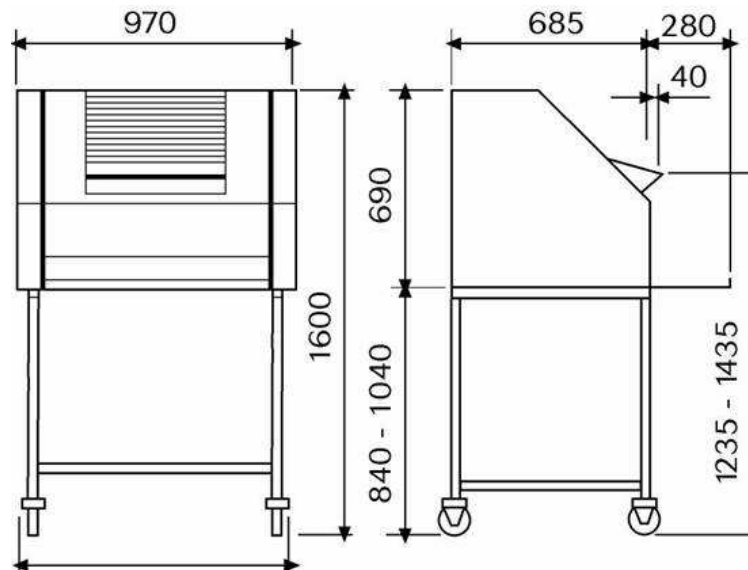

Contact Details

HEAD OFFICE, EXPORTS & CAPE TOWN BRANCH Tel : +27 (21) 907-1000 Fax : +27 (21) 907-1111

JOHANNESBURG BRANCH Tel : (011) 472-4100 Fax : 086 618 6462

DURBAN BRANCH Tel : (031) 569-6290 Fax : (031) 569-6296

EMAIL info@macadams.co.za

WEBSITE www.macadams.co.za



Macadams

Mac 500 Roll Moulder



FEATURES & BENEFITS

- Durable construction.
- Safe and easy to operate.
- Suited for smaller and medium sized bakeries.
- Even and consistent output.





Technical Specs

| | MAC 5000 |
|-----------------------------------|---|
| Power Rating (kW) | 0.75 |
| Power Supply | 400 V, 50 Hz 3 phase, neutral and earth. Other voltages available on request. |
| Current Rating at 400 V | 2 A |
| Weight Range for Dough Pieces (g) | 30 - 500 |
| Moulding Length (mm) | Up to 450 |
| Adjustable Roller Gap (mm) | 0 - 20 |
| Dimensions (mm) | 810 (W) x 1130 (D) x 1240 (H) |
| Weight (kg) | 115 |

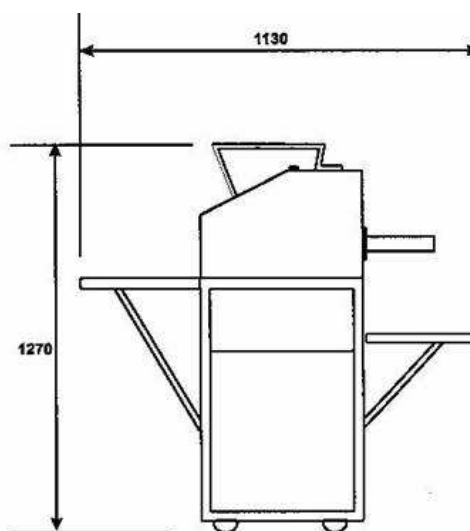
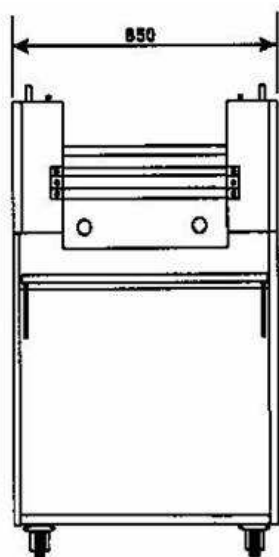

Contact Details

HEAD OFFICE, EXPORTS & CAPE TOWN BRANCH Tel : +27 (21) 907-1000 Fax : +27 (21) 907-1111

JOHANNESBURG BRANCH Tel : (011) 472-4100 Fax : 086 618 6462

DURBAN BRANCH Tel : (031) 569-6290 Fax : (031) 569-6296

EMAIL info@macadams.co.za

WEBSITE www.macadams.co.za



Macadams

Macmoulder



FEATURES & BENEFITS

- Simple controls.
- Durable construction.
- Safety features.





Technical Specs

| MACMOULDER | |
|----------------------------|---|
| Power Rating (kW) | 0.55 |
| Power Supply | 400 V, 50 Hz, 3 phase, neutral and earth Other voltages on request. |
| Current Rating at 400 V | 1 A |
| Dough Weight Range (g) | 100 - 900 |
| Moulding Length (mm) | Up to 400 |
| Adjustable Roller Gap (mm) | 0 - 20 |
| Dimensions (mm) | 550 (W) x 1200 (D) x 1260 (H) |
| Weight (kg) | 135 |

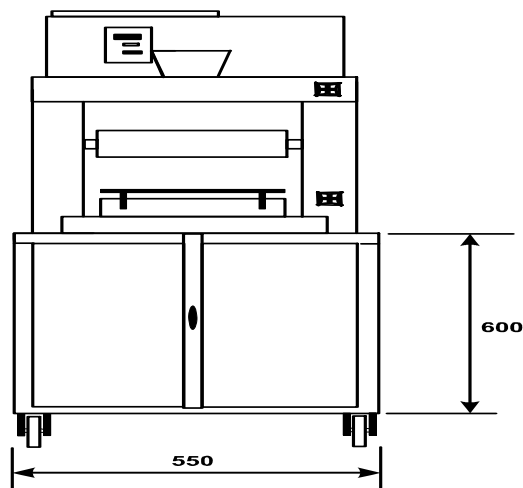
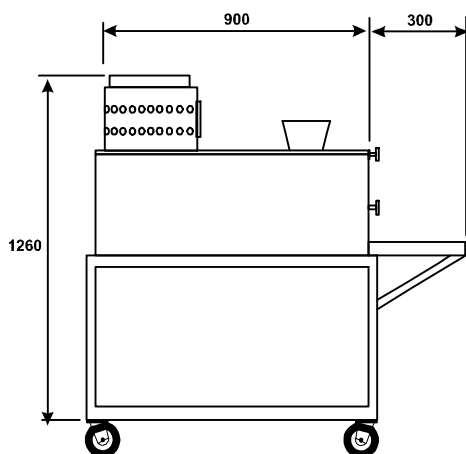

Contact Details

HEAD OFFICE, EXPORTS & CAPE TOWN BRANCH Tel : +27 (21) 907-1000 Fax : +27 (21) 907-1111

JOHANNESBURG BRANCH Tel : (011) 472-4100 Fax : 086 618 6462

DURBAN BRANCH Tel : (031) 569-6290 Fax : (031) 569-6296

EMAIL info@macadams.co.za

WEBSITE www.macadams.co.za



Macadams

Mini Bread & Roll Moulder

With 4 Piece Attachment

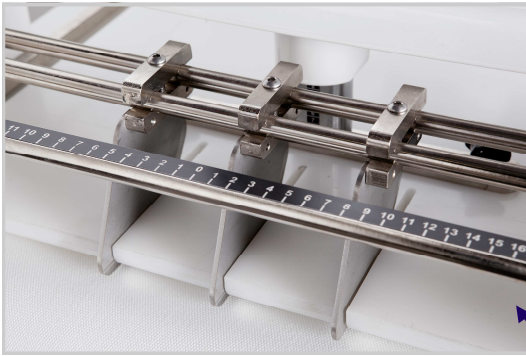

FEATURES & BENEFITS

- Stainless steel in-feed chute with safety guard.
- Easy pressure board adjustment.
- Adjustable side guide rails.
- On castors.
- Stainless steel out-feed catch tray.
- Clear plastic safety covers.

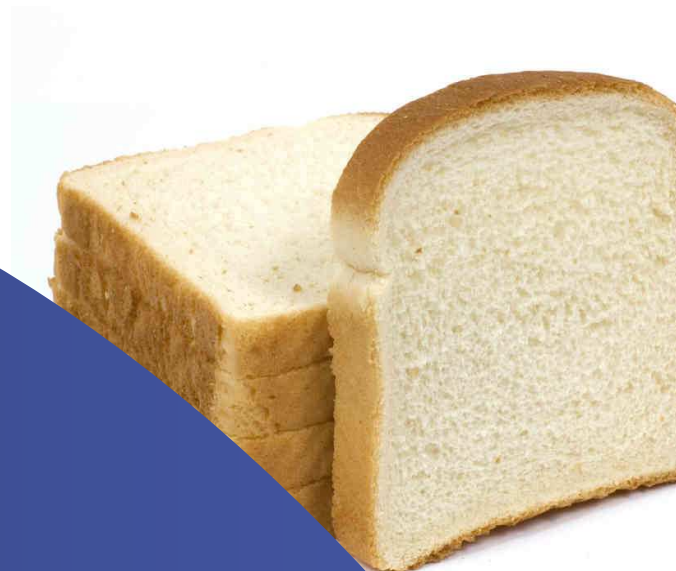

| Mini Bread & Roll Moulder With 4 piece attachment | |
|--|---|
| Power Rating (kW) | 0.55 |
| Power Supply | 400 V, 50 Hz 3 phase, neutral and earth. Other voltages on request. |
| Current Rating at 400 V | 1 A |
| Dough Weight Range (g) | 60 - 900 |
| Moulding Length (mm) | Up to 450 |
| Adjustable Roller Gap (mm) | Top : 10 - 20 Bottom : 0 - 12 |
| Dimensions (mm) | 650 (W) x 1680 (D) x 1610 (H) |
| Weight (kg) | 167 |

Advantages of 4 piece moulding attachment:

4 Piece Moulding Attachment:

- White colour
- Better Buttering Qualities
- Finer Crumb Structure
- Strengthened Bread Structure

Standard Bread Moulding:

- Bland Colour
- Difficult Buttering Qualities
- Larger Crumb Structure
- Collapsed sides after 24 hours

Results of 4 piece bread with same dough versus current bread moulding solution

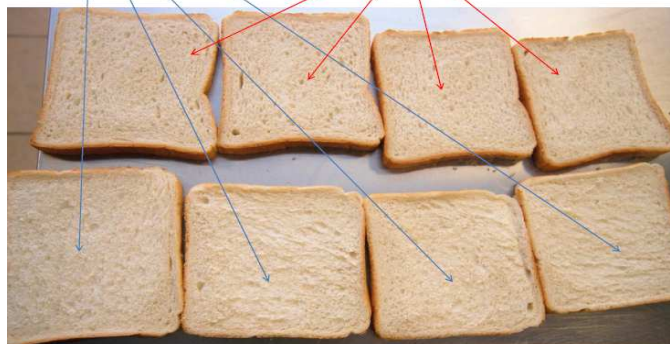

Contact Details

HEAD OFFICE, EXPORTS & CAPE TOWN BRANCH Tel : +27 (21) 907-1000 Fax : +27 (21) 907-1111

JOHANNESBURG BRANCH Tel : (011) 472-4100 Fax : 086 618 6462

DURBAN BRANCH Tel : (031) 569-6290 Fax : (031) 569-6296

EMAIL info@macadams.co.za

WEBSITE www.macadams.co.za



Macadams

Mini Bread & Roll Moulder



FEATURES & BENEFITS

- Easy pressure board adjustment.
- Adjustable side guide rails
- Stainless steel out-feed catch tray.
- On castors.
- Clear plastic safety covers.
- Stainless steel in-feed chute with safety guard.



| MINI STATUS MOULDER | |
|-------------------------|---|
| Power Rating | 0.55 kW |
| Power Supply | 230 / 400 V, 50 Hz, 3 phase, neutral and earth. Other voltages on request. |
| Current Rating at 400 V | 1 Amp |
| Dough Weight Range | 60 - 900 g |
| Moulding Length | Up to 450 mm |
| Adjustable Roller Gap | Top : 10 - 20 mm Bottom : 0 - 12 mm |
| Dimensions (mm) | 650 (w) x 1680 (d) x 1610 (h) |
| Weight | 167 kg |

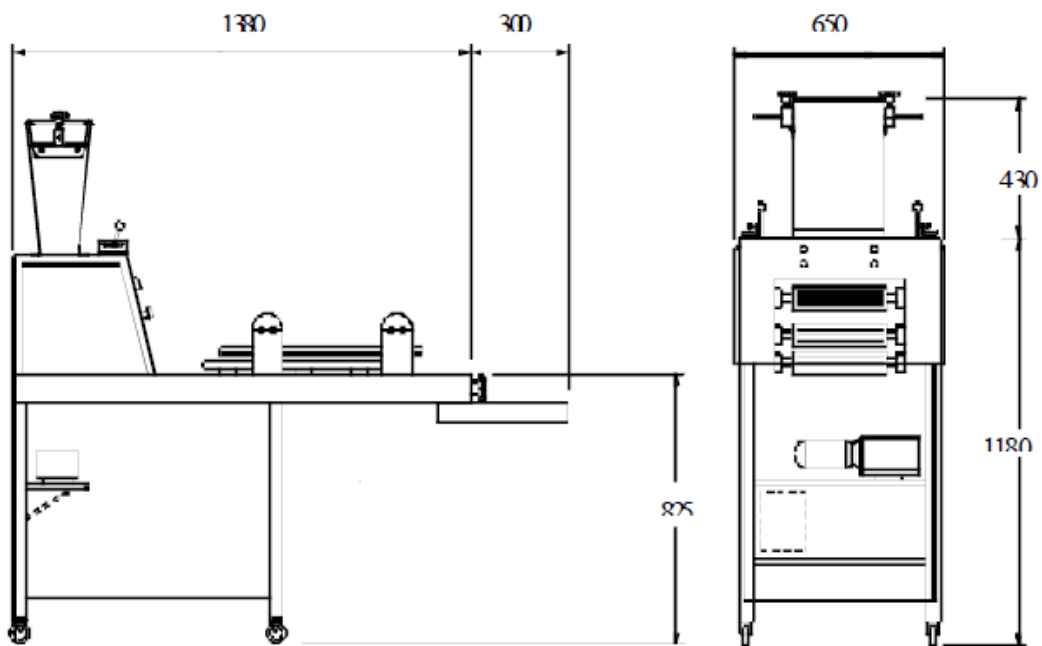

Contact Details

HEAD OFFICE, EXPORTS & CAPE TOWN BRANCH Tel : +27 (21) 907-1000 Fax : +27 (21) 907-1111

JOHANNESBURG BRANCH Tel : (011) 472-4100 Fax : 086 618 6462

DURBAN BRANCH Tel : (031) 569-6290 Fax : (031) 569-6296

EMAIL info@macadams.co.za

WEBSITE www.macadams.co.za